



SERIES 37 DIAPHRAGM VALVES

STRAIGHT THROUGH TYPE - SCREWED

DN25 - DN80 RISING HAND WHEEL



KDV's range of bi directional Straight Through Type diaphragm valves offer exceptional durability and reliability. The clean design completely isolates line media from the mechanical components of the valve. Bubble tight shutoff (Class VI) and in-line serviceability (top entry) maximise plant efficiency and productivity.

KDV Straight Through Type diaphragm valves are suited to on-off and control applications and can be custom specified to suit a wide variety of applications.

Contact your KDV technical sales representative to ascertain the correct valve and lining options for your specific application.

Designed & Manufactured by KDV

KDV Diaphragm valves are manufactured to international standards. Precision machining and strict quality control ensure consistency, reliability and durability.

COMMON APPLICATIONS

- Slurries
- Water and waste water
- Organic sludge
- Effluent treatment
- Lime solutions
- Cement
- Ceramics
- Sugar
- Mineral Sands
- Mining/Minerals Processing

FEATURES & BENEFITS

- Bubble-tight shutoff
- Easy/low maintenance
- Readily available spare parts
- In-line serviceable (top entry)
- Cavity free design
- Position indicator
- Excellent control characteristics
- Low fugitive emissions
- No stem seal leakage
- Line media isolated from valve mechanicals
- Tamper proof over closure protection

OPERATOR OPTIONS

- Lockable device (for isolation)
- Sealed bonnet
- Extension spindle
- Chain wheel

AUTOMATION SYSTEMS

- Pneumatic (fail open, fail closed, double acting)
- Electric
- Hydraulic

OPTIONS

- Range of body materials
- Specialty coatings to suit a variety of environmental requirements
- Internal linings and coatings
- Range of bonnet materials

FAST TRACK

In house manufacture and stock holdings allow KDV to deliver quickly, and reliably facilitate fast-track projects. Visit our website for information on the full range of KDV Diaphragm Valves.

www.kdvflow.com



SERIES 37 DIAPHRAGM VALVES

STRAIGHT THROUGH TYPE - SCREWED

DN25 - DN80 RISING HAND WHEEL

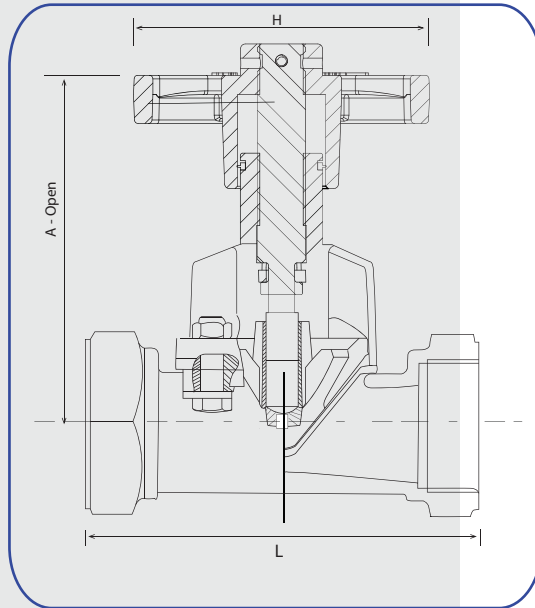
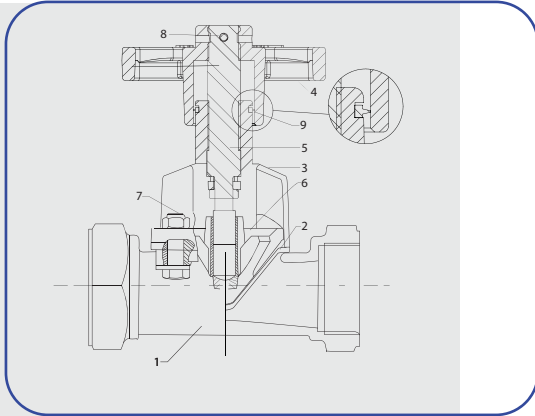

MATERIALS OF CONSTRUCTION

PART	MATERIAL
1 Body	Cast Iron, Cast Ductile Iron
2 Diaphragm	See Below ¹
3 Bonnet Shell	Cast Iron, Ductile Iron
4 Hand Wheel	Cast Iron, Ductile Iron
5 Spindle	SS304
6 Compressor	Cast Iron, Ductile Iron
7 Fasteners	ISO Grade 8.8
8 Handwheel Pin	Mild Steel
9 Environmental Seal*	EPDM Wiper Seal

*Environmental seal bonnet not available on all bonnet sizes.
Ask your KDV sales representative for more information.

DIMENSIONS & WEIGHTS

Valve	L	A	H	Weight (kg)
DN25	111	149	124	3.0
DN32	121	147	124	3.5
DN40	143	151	124	3.5
DN50	168	188	170	7.0
DN80	254	262	240	16.0

PRESSURE RATING

Valve	Pressure
DN25 - DN80	10 Bar

DIAPHRAGM MATERIALS¹

- 10 - Natural rubber (NR)
- 20 - EPDM rubber
- 30 - Butyl rubber (IIR)
- 40 - Nitrile rubber (NBR)
- 50 - Neoprene rubber (CR)
- 60 - Hypalon rubber (CSM)
- 70 - Viton rubber (FKM/FPM)

NB: Vacuum grade diaphragms available on request

MATERIAL SPECIFICATIONS

- Cast Iron (ASTM A126 Gr CI B)
- Cast Ductile Iron (ASTM A395 Gr 60-40-18)
- Carbon Steel (ASTM A216 Gr WCB)
- Stainless Steel (ASTM A351 Gr CF8, CF8M, CF3, CF3M)

THREAD STANDARDS

- ANSI B2.1 NPT
- AS1722.1 Part1 BSPP

TESTING STANDARDS

- EN12266-1 2002(BS6755 Part 1)

DESIGN STANDARDS

- EN13397-2001 (BS5156:1985)

Note 1: Specifications contained in this document are subject to change.
Note 2: For precise specifications and dimensions contact KDV to obtain a general assembly drawing.